

RELIANCE[®]

CONTROLS



WP02
PRODUCT CATALOG



EXTRA DUTY IN-USE WEATHERPROOF OUTLET COVERS

CEILING FAN AND LIGHT FIXTURE SUPPORT BOXES

FLAT SCREEN TV KITS & CORD AND CABLE MANAGEMENT

CIRCUIT TESTERS AND HOME MONITORING PRODUCTS



ELECTRICAL INNOVATION SINCE 1909



Reliance Controls Corporation has been manufacturing high-quality electrical products since 1909. We have built a strong reputation not only for the quality of our products, but also the manner in which we conduct our business. We strive to exceed the expectations of our customers.



Products in this catalog are listed by Underwriters Laboratories, Inc. and are suitable for use in accordance with U.S. and Canadian National Electric Codes.

CONTENTS

EXTRA-DUTY In-Use Weatherproof Covers

Plastic Single and Double Gang	
● CW1PC Single Gang Gray / Clear	6
● CW1PCW Single Gang White / Clear	6
● CW1PG Single Gang Gray / Gray	6
● CW1PW Single Gang White / White	6
● CW1PB Single Gang Bronze / Bronze	6
● CW2PC Double Gang Gray / Clear	6
● CW2PG Double Gang Gray / Gray	6

Plastic Adapter Plate

● CAP1PG Single Gang Adapter Plate / Gray	6
---	---

Plastic Single and Double Gang Low Profile Expandable

● CW1PLPG Single Gang Gray / Clear	8
● CW1PLPW Single Gang White / Clear	8
● CW1PLPB Single Gang Bronze / Clear	8
● CW2PLPG Double Gang Gray / Clear	8

Plastic Single Gang Super Deep Cover

● CW1PDC Single Gang Gray / Clear	9
-----------------------------------	---

Metal Single and Double Gang

● CW1MVG Single Gang Vertical Gray / Gray	10
● CW1MHG Single Gang Horizontal Gray / Gray	10
● CW1MDVG Single Gang Vertical Deep Gray / Gray	10
● CW2MG Double Gang Gray / Gray	10

Plastic and Metal Flat Covers

● CW1PFC Single Gang / Clear	11
● CW2PFC Double Gang / Clear	11
● CW1MFVG Single Gang Vertical / Gray	11
● CW1MFVW Single Gang Vertical / White	11
● CW1MFVB Single Gang Vertical / Bronze	11
● CW2MFG Double Gang / Gray	11

Ceiling Fan and Light Fixture Support Boxes

Metal with Metal Cover

● FB105 1/2" x 4"	14
● FB115 1 1/2" x 4"	14
● FB121 2 1/8 x 4"	14

Plastic with Plastic Cover

● FB213 12 Cubic Inch x 4"	14
----------------------------	----

Metal with Metal Cover with Side Mount Bracket

● FB215 1/2" x 4"	15
● FB221 2 1/8 x 4"	15

Metal with Metal Cover Stud-Span Brace Kits

● FB315 1/2" x 4" New Construction	15
● FB321 2 1/8 x 4" New Construction	15
● FB415 1/2" x 4" Remodel	15
● FB421 2 1/8 x 4" Remodel	15

Flat Screen TV Cord and Cable Management Kits

● EC100 TV Cord Cover Kit / On Wall	18
● EC200 Low Volt Cable Installation Kit / In-Wall	18
● EC300 High and Low Volt Cable Installation Kit / In-Wall	18
● CA110 For on-wall mounting of single conductor wires	18
● CA210 For on-wall mounting of multiple conductor wires	18

Circuit Testers & Home Monitoring Products

● THP101 Non-Contact Voltage Tester	22
● THP109 Circuit Scout Circuit Breaker Locator	22
● THP103 AmWatt Appliance Load Tester	22
● THP102 Plug-In Circuit Analyzer & GFCI Check	22
● THP102P Plug-In Circuit Analyzer & GFCI Check w/40" Cord	22
● THP105 PIVI Plug-In Voltage Indicator	22
● THP207M PowerOUT Power Failure Alarm and Flashlight	23
● THP205 Sump Pump Alarm and Flood Alert	23
● THP111 SoniCORD Key Appliance Power Failure Alarm	23
● THP217 Phone Out Freeze and Power Outage Call-Out	23
● THP108 PowerBACK Utility Power Return Alarm	23

EXTRA DUTY IN-USE WEATHERPROOF COVERS

For commercial and residential use

Model Numbering System

Reliance Controls EXTRA-DUTY Plastic and Die-Cast Aluminum Weatherproof Covers are built tough to keep 125 and 250 Volt receptacles dry, clean and undamaged for years of steady commercial and residential use. Patented features of our covers allow the greatest number of outlet configurations and let you maintain the most debris and insect free compartments possible.

Reliance EXTRA-DUTY Weatherproof Covers are available in strong polycarbonate single and double-gang, expandable low profile and super deep housing enclosures. We also offer a full line of single and double-gang die-cast aluminum horizontal and vertical enclosure types.

Our Weatherproof Covers are built to meet or exceed NEC 2017 building standards outlined in Article 406.9 (B)(1) for wet locations and EXTRA-DUTY applications and CEC 2015 Section 26-702.

MODEL NUMBERING SYSTEM

SAMPLE MODEL NO.

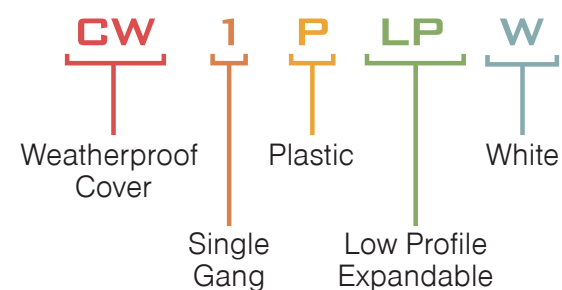

BUILT TOUGH TO KEEP YOUR OUTDOOR POWER OUTLETS DRY CLEAN & UNDAMAGED DURING STEADY HARD USE



PLASTIC EXTRA-DUTY

IN-USE WEATHERPROOF COVERS

PLASTIC EXTRA-DUTY

IN-USE WEATHERPROOF COVERS



Item#	Description	Color	Material	Depth	UPC	Pack Qty.
CW1PC	1-Gang vertical or horizontal extra-duty in-use cover with 16 installation combinations	Gray/Clear	Plastic	3"	8-15181-01271-7	8
CW1PCW		White/Clear	Plastic	3"	8-15181-01625-8	8
CW1PG		Gray	Plastic	3"	8-15181-01270-0	8
CW1PB		Bronze	Plastic	3"	8-15181-01792-7	8
CW1PW		White	Plastic	3"	8-15181-01625-8	8
CAP1PG	Single Gang Cover to Round Box Adapter	Gray	Plastic	N/A	8-15181-01767-5	20



Item#	Description	Color	Material	Depth	UPC	Pack Qty.
CW2PC	2-Gang square extra-duty in-use cover with 73 installation combination	Gray/Clear	Plastic	3"	8-15181-01271-7	8
CW2PG		Gray	Plastic	3"	8-15181-01625-8	8

- 
 Vertical & Horizontal Application
- 
 Extra-Duty Weatherproof Protection
- 
 Extended-Life High-Impact Polycarbonate Construction
- 
 Patent Pending Quick-Snap Adapter System
- 
 Patent Pending Hinge System

Reliance Controls nonmetallic in-use covers meet and exceed NEC requirements for Extra-Duty protection.

16 in 1 CONFIGURATIONS

- Vertical & Horizontal Application
- Attached Gasket
- Fits Full Size Locks
- Hinge Pins
- Hardware
- Duplex
- Extra-Duty Weatherproof Protection
- Cord Port Guards
- GFCI Decorator
- GFCI Decorator
- Blank Toggle Round 1-1/4" Round 1-3/8" Round 1-9/16"
- Blank Toggle Round 1-1/4" Round 1-3/8" Round 1-9/16"
- Large Toggle Round 1-1/4" Round 1-3/8" Round 1-9/16" Round 1-5/8" Round 1-11/16" Round 2-1/8" Round 2-1/4" Round 2-7/16"
- Patent Pending Snap-In Hinge System
- Patent Pending Quick-Snap Adapter System
- 73 in 1 CONFIGURATIONS
- Extended-Life High-Impact Polycarbonate Construction

cUL US LISTED

DIMENSIONS

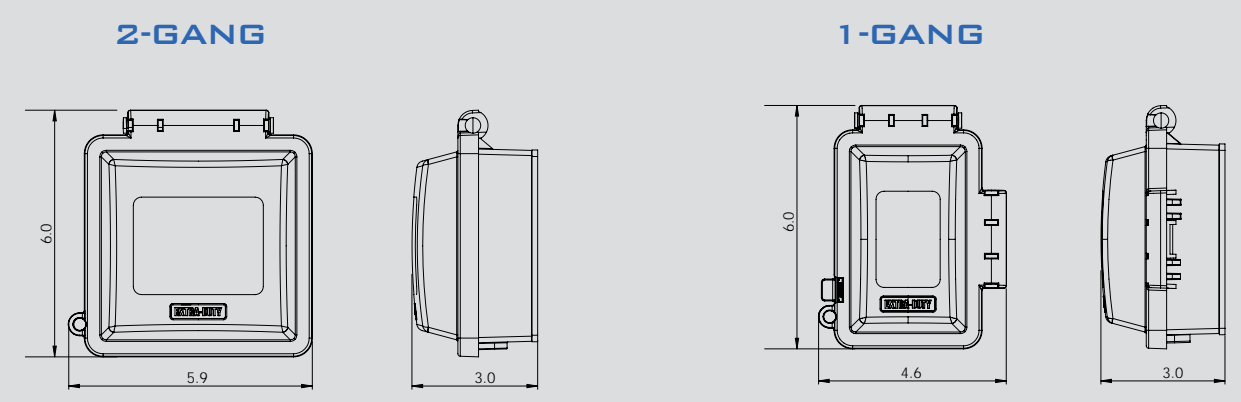

PLASTIC EXTRA-DUTY IN-USE WEATHERPROOF COVERS

PLASTIC EXTRA-DUTY EXPANDABLE

LOW-PROFILE IN-USE WEATHERPROOF COVERS

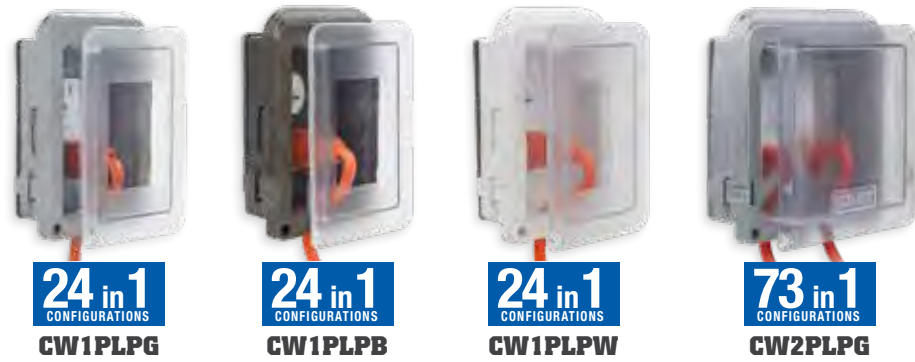

- Low-profile design with patented slide-out cover for cord plug-in
- Clear window allows for visual inspection
- Patented Slide-Out / Slide-In Cord Port Guards
- Includes attached gasket and mounting hardware

NEMA 3R
Rated



Item#	Description	Color	Material	Depth	UPC	Pack Qty.
CW1PLPG	1-Gang extra-duty low-profile expandable in-use cover (24 in 1)	Gray / Clear	Plastic	1-3/4" - 3"	8-15181-01767-5	10
CW1PLPB		Bronze / Clear	Plastic	1-3/4" - 3"	8-15181-01794-1	10
CW1PLPW		White / Clear	Plastic	1-3/4" - 3"	8-15181-01793-4	10
CW2PLPG	2-Gang low-profile in-use cover (73 in 1)	Gray / Clear	Plastic	1-3/4" - 3"	8-15181-01795-8	6

Lockable Hasp: Fits Full Size Locks

Expandable nonmetallic commercial in-use covers meet and exceed NEC requirements for Extra-Duty protection.



DIMENSIONS

1-GANG

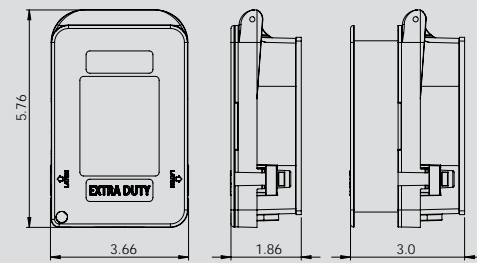

2-GANG

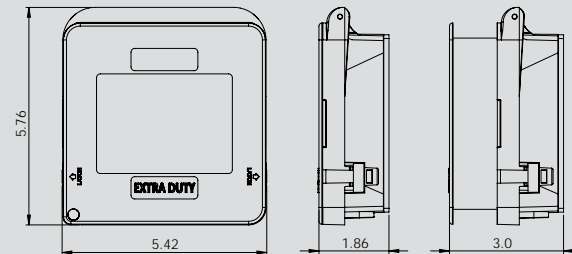

PLASTIC EXTRA-DUTY SUPER DEEP

IN-USE WEATHERPROOF COVER

Reliance Controls nonmetallic super-deep in-use covers meet and exceed NEC requirements for Extra-Duty protection. For larger cords up to 12 AWG and longer plugs.

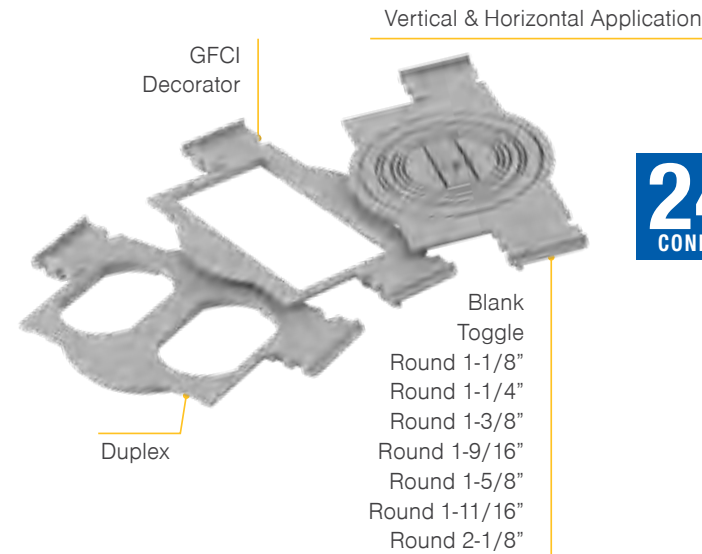

24 in 1
CONFIGURATIONS

Patent Pending Snap-In Hinge System



NEMA 3R
Rated



Item#	Description	Color	Material	Depth	UPC	Pack Qty.
CW1PDC	1-Gang super-deep extra-duty in-use cover (24 in 1)	Gray / Clear	Plastic	5"	8-15181-01766-8	4



DIMENSIONS

1-GANG SUPER DEEP

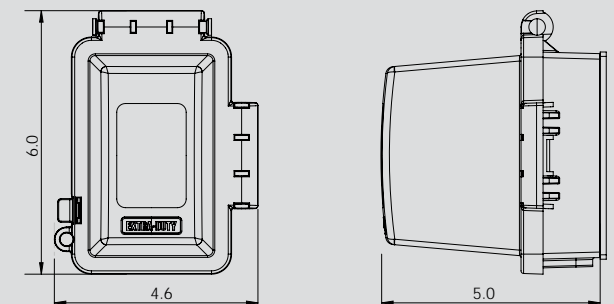

PLASTIC EXTRA-DUTY SUPER-DEEP IN-USE WEATHERPROOF COVER

METAL EXTRA-DUTY

IN-USE WEATHERPROOF COVERS

FLAT

WEATHERPROOF COVERS



12 in 1 CONFIGURATIONS
CW1MVG

12 in 1 CONFIGURATIONS
CW1MHG

12 in 1 CONFIGURATIONS
CW1MDVG

73 in 1 CONFIGURATIONS
CW2MG

Item#	Description	Color	Material	Depth	UPC	Pack Qty.
CW1MVG	1-Gang vertical in-use cover (12 in 1)	Gray	Metal	3.64"	8-15181-01770-5	6
CW1MHG	1-Gang horizontal in-use cover (12 in 1)	Gray	Metal	3.64"	8-15181-01797-2	4
CW1MDVG	1-Gang vertical deep in-use cover (12 in 1)	Gray	Metal	4.64"	8-15181-01772-9	2
CW2MG	2-Gang in-use cover (73 in 1)	Gray	Metal	3.64"	8-15181-01773-6	2

- Commercial and Residential applications.
- Patented Cord-Port Guards built into base
- Includes attached gasket and mounting hardware.
- Cover Hinge Pin Hang Test: Tested to greater than 40 lb.
- Cover Impact Test: Tested to 12 lbs.



Extra-Duty
Weatherproof
Protection



For up to
12 AWG cords



Patent Pending
Quick-Snap
Adapter System



DIMENSIONS

1-GANG VERTICAL

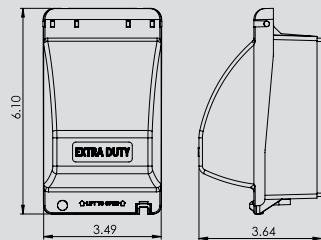

1-GANG HORIZONTAL

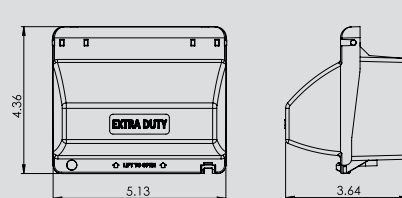

1-GANG VERTICAL DEEP

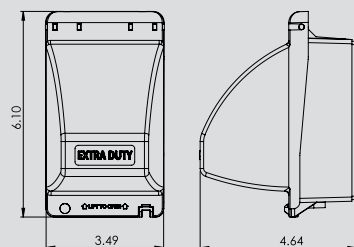

2-GANG

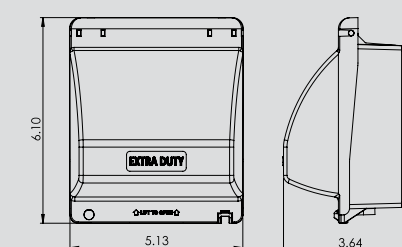

73 in 1 CONFIGURATIONS
CW2MFG

73 in 1 CONFIGURATIONS
CW2PFC

24 in 1 CONFIGURATIONS
CW1MFVB

24 in 1 CONFIGURATIONS
CW1MFVW

24 in 1 CONFIGURATIONS
CW1MFVG

24 in 1 CONFIGURATIONS
CW1PFC

Item#	Description	Color	Material	Depth	UPC	Pack Qty.
CW1PFC	1-Gang horz/vert flat cover (24 in 1)	Gray/ Clear	Plastic	0.90"	8-15181-01768-2	10
CW1MFVG	1-Gang horz/vert Flat Cover (24 in 1)	Gray	Metal	0.93"	8-15181-01774-3	20
CW1MFVW	1-Gang horz/vert Flat Cover (24 in 1)	White	Metal	0.93"	8-15181-01796-5	20
CW1MFVB	1-Gang horz/vert Flat Cover (24 in 1)	Bronze	Metal	0.93"	8-15181-01798-9	20
CW2PFC	2-Gang flat cover (73 in 1)	Gray/ Clear	Plastic	0.90"	8-15181-01769-9	10
CW2MFG	2-Gang flat cover (73 in 1)	Gray	Metal	0.93"	8-15181-01775-0	6

- Residential and commercial applications.
- Includes attached gasket and mounting hardware.

DIMENSIONS

1-GANG METAL

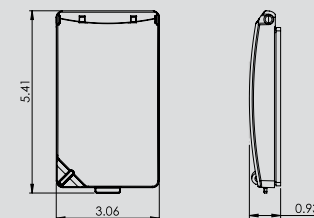

2-GANG METAL

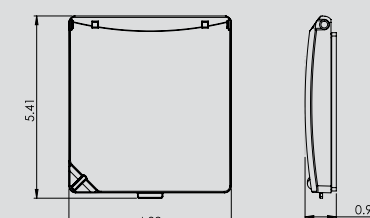

1-GANG PLASTIC

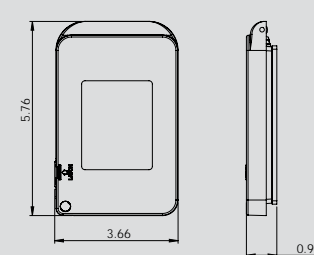

2-GANG PLASTIC

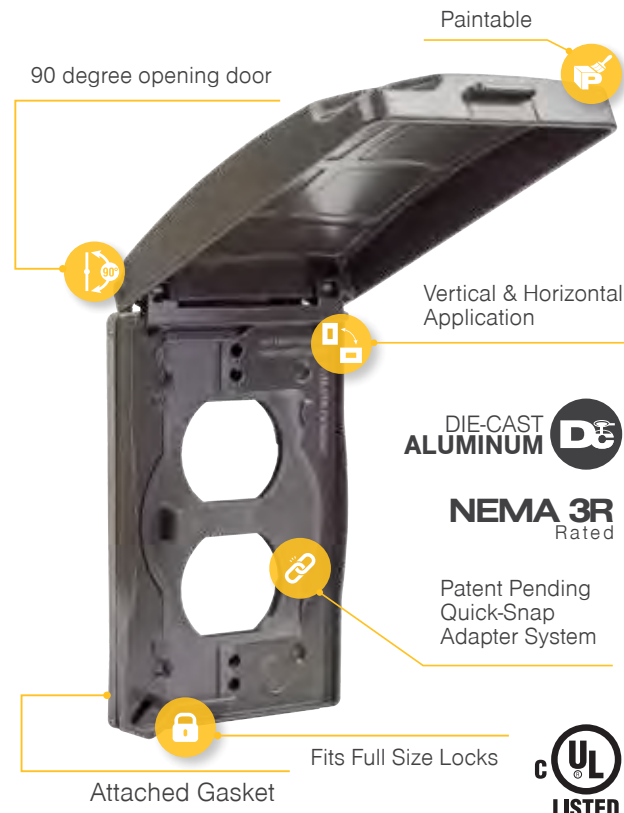
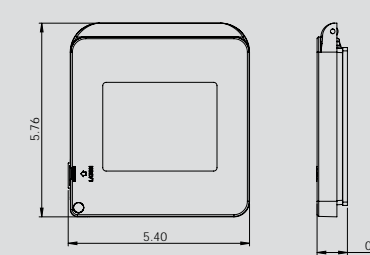

CEILING FAN & LIGHT FIXTURE SUPPORT BOXES

**NEW CONSTRUCTION OR
REMODELING - SECURE
YOUR CEILING FIXTURES
AND FANS WITH
RELIANCE CONTROLS
INNOVATION**



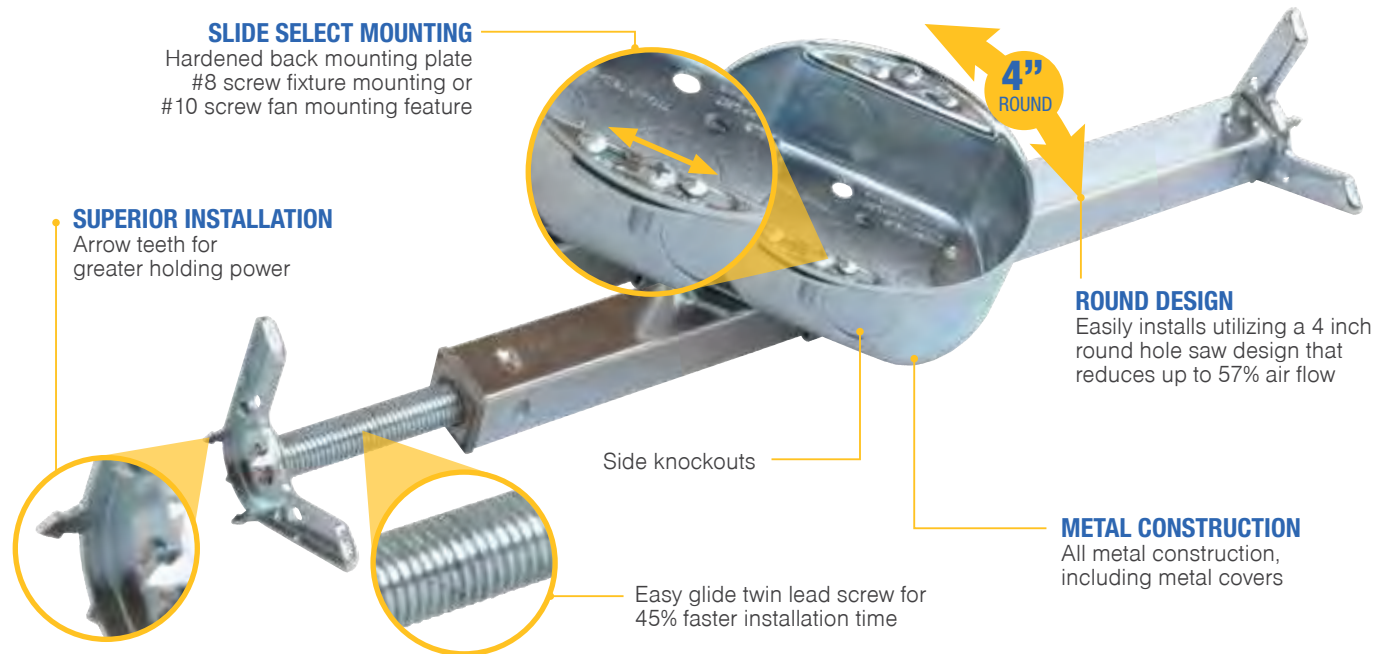

ROUND BOXES

- For New Construction and Remodel Applications
- Protective Metal Cover Eliminates Debris or Damage to Wiring
- Max. Ceiling Fan Weight 70 lbs
- Max. Light Fixture Weight 150 lbs

Item#	Description	Depth	Width	UPC	Pack Qty.
FB105	Ceiling fan and light fixture support box with metal cover	1/2"	4"	8-15181-01179-6	12
FB115		1-1/2"	4"	8-15181-01180-2	12
FB121		2-1/8"	4"	8-15181-01181-9	12



STUD MOUNT

- For New Construction and Remodel Applications
- One-Sided Stud Mount with 3.5 in Length and Removable Joist Holding Tabs
- Protective Plastic Cover Eliminates Debris or Damage to Wiring
- Max. Ceiling Fan Weight 70 lbs
- Max. Light Fixture Weight 210 lbs

Item#	Description	Cu. In.	Width	UPC	Pack Qty.
FB213	Stud Mount ceiling fan and light fixture support box with plastic cover	12	4"	8-15181-01184-0	12

SIDE MOUNT

- For New Construction and Remodel Applications
- Protective Metal Cover Eliminates Debris or Damage to Wiring
- Max. Ceiling Fan Weight 70 lbs
- Max. Light Fixture Weight 150 lbs



Item#	Description	Depth	Width	UPC	Pack Qty.
FB215	Side mount ceiling fan and light fixture support box with metal cover	1-1/2"	4"	8-15181-01182-6	4
FB221		2-1/8"	4"	8-15181-01183-3	4

NEW WORK BRACE

- For New Construction Applications
- Protective Metal Cover Eliminates Debris or Damage to Wiring
- Max. Ceiling Fan Weight 70 lbs
- Max. Light Fixture Weight 150 lbs on 16 in Centers
- Max. Light Fixture Weight 90 lbs on 24 in Centers



Item#	Description	Depth	Width	UPC	Pack Qty.
FB315	Ceiling fan and light fixture support box with metal cover for new construction applications	1-1/2"	4"	8-15181-01186-4	12
FB321		2-1/8"	4"	8-15181-01187-1	12

OLD WORK BRACE

- For Remodel Applications
- Greater holding power featuring 12 total gripping teeth
- Easy Glide Twin Lead Screw for Fast Installation
- Max. Ceiling Fan Weight 70 lbs
- Max. Light Fixture Weight 150 lbs on 16 in Centers
- Max. Light Fixture Weight 50 lbs on 24 in Centers

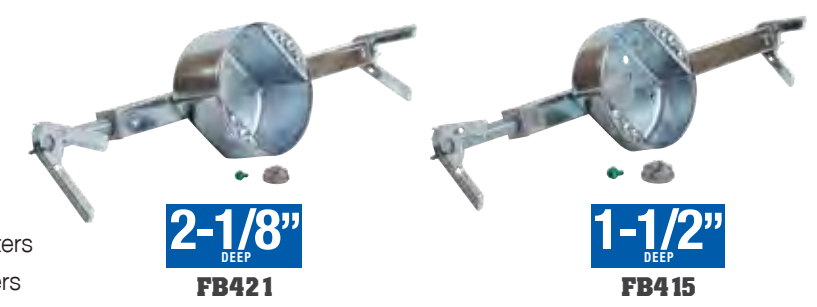

Item#	Description	Depth	Width	UPC	Pack Qty.
FB415	Ceiling fan and light fixture support box with metal cover for remodel applications	1-1/2"	4"	8-15181-01188-8	12
FB421		2-1/8"	4"	8-15181-01189-5	12



CABLE MANAGEMENT KITS

For Flat Screen TV & Appliance Cord Concealment

**MAKE CORD CLUTTER
DISAPPEAR WITH THESE
EASY-TO-INSTALL
RELIANCE KITS**

CABLE MANAGEMENT KITS





EC100

ON-WALL KIT

- Conceals all TV cords and wires with one decorative panel.
- Integrated springs apply pressure over the entire length of the cover preventing cover from slipping down the wall.
- Easy installation with pre-drilled mounting holes.

Item#	Description	Color	UPC	Pack Qty.
EC100	On-the-Wall Cover for Power Cords & AV Cables	White	8-15181-01176-5	5

4ft
CHANNEL



Paintable Surface



Patented design holds cover tight to prevent slipping down the wall.



EC200

IN-WALL LOW-VOLTAGE KIT

- Easily hides low voltage cables such as HDMI.
- Fast and simple installation
- Air-Free™ Memory Foam Technology ensures energy efficiency. The Memory Foam inserts help prevent the flow of conditioned-air into the wall space PLUS the boxes are gasketed to prevent air loss.
- Complete kit includes hole saw, wire fishing sticks, flexible conduit and air-free insulated opening covers

Item#	Description	Color	UPC	Pack Qty.
EC200	In-the-Wall Low-Voltage Cable Installation Kit	White	8-15181-01177-2	3



Air-Free™ Memory Foam Inserts



Paintable Surface



EC300

IN-WALL POWER & LOW-VOLTAGE KIT

- Air-Free™ Technology - Restricts the free exchange of interior and exterior air.
- EZ-Connect Technology - Self contained power outlet for convenient power connection.
- EZ-Feed Technology - 3.5" in wall tube for EZ-Feeding of plugs and cables.
- Complete kit includes hole saw, wire fishing sticks, power cord, wall tubing and air-free electrical outlets

Item#	Description	Color	UPC	Pack Qty.
EC300	Flat Screen TV In-the-Wall Low-Voltage plus Power Cable Kit	White	8-15181-01178-9	3



Air-Free™ Technology



Paintable Surface



EZ-Feed Technology



For Patent information, go to www.reliancecontrols.com/Patents

CONFORMS TO
UL STD 514C
& CSA STD
C22.2 #18.2



EC100



EC200



EC300

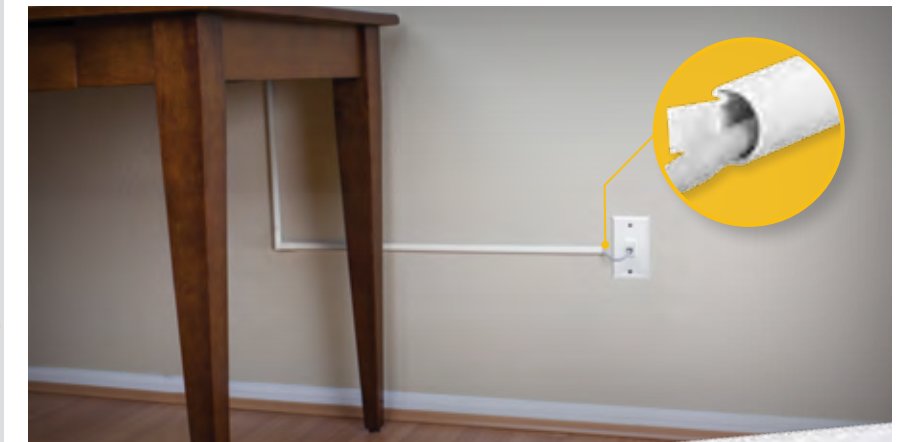

SINGLE CORD CHANNEL MANAGEMENT KIT

CA110

- For covering, routing and protecting single cords

Item#	Description	Color	UPC	Pack Qty.
CA110	Single Cord Channel Management Kit - 3 foot adhesive-backed sections	White	8-15181-01748-4	10

- Contains - 3 - 3-Foot Channels, 2 - Flat Elbows, 1 - Inside elbow, 1 - Outside Elbow, 2 - Couplings

Paintable Surface

3ft
CHANNEL

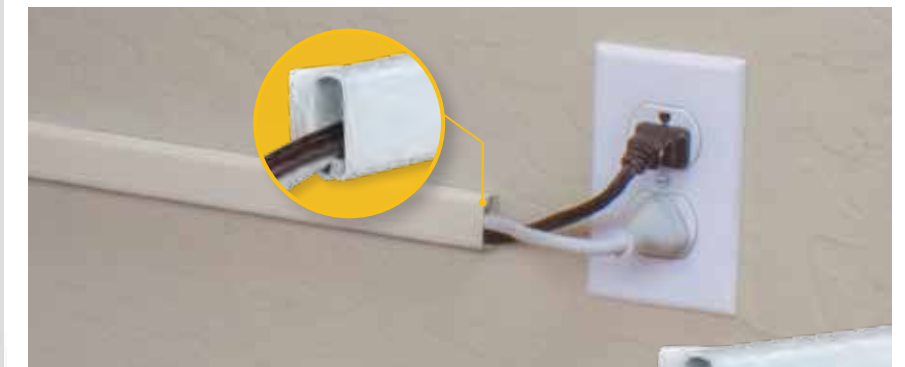

MULTIPLE CORD CHANNEL MANAGEMENT KIT

CA210

- For covering, routing and protecting multiple cords

Item#	Description	Color	UPC	Pack Qty.
CA210	Multiple Cord Channel Management Kit - 4-foot adhesive backed sections	White	8-15181-01749-1	5

- Contains - 3 - 4-Foot Channels, 2 - Flat Elbows, 1 - Inside Elbow, 1 - Outside Elbow, 2 - Couplings, 1 - T-Fitting

Paintable Surface

4ft
CHANNEL

CIRCUIT TESTERS & HOME MONITORING PRODUCTS

By listening to our customers as they prepare and react to power outages, we've developed this innovative group of electrical **CIRCUIT TESTERS**. We designed them to make generator transfer switch installation as well as everyday electrical jobs easier and safer.

Our storm-related **HOME MONITORING PRODUCTS** warn you of power outages and home flooding, alert you to accidental power interruption to important plug-in devices and even phone you anywhere if the temperature in your home or cabin approaches freezing.





VOLT SNOOPER NON-CONTACT VOLTAGE DETECTOR

Item#	Description	UPC	Pack Qty.
THP101	Non-Contact Voltage Detector	8-51890-00001-0	10

- Handy pen-size device checks for the presence of live voltage between 50-1000 AC Volts (50-60 Hz) without need to contact bare wire leads.
- Visual and audible signal indicates current.
- Pushbutton activation of voltage detection.



CIRCUIT SCOUT CIRCUIT BREAKER LOCATOR

Item#	Description	UPC	Pack Qty.
THP109	Circuit Breaker Locator	8-15181-01277-9	5

- Electrician-inspired plug-in device for detection of the right circuit breaker the first time, every time.
- Eliminates need for a second person on the job.
- Plug the Circuit Scout into the outlet you want to trace. Turn on sonic and increase volume as needed. Then go turn off the correct breaker to stop sonic.
- Built in wiring analyzer.



AMWATT PLUG-IN APPLIANCE LOAD TESTER

Item#	Description	UPC	Pack Qty.
THP103	Plug-In Appliance Load Tester	8-51890-00004-1	3

- Instant reading of either Watts or Amps used by any plug-in device.
- Determine the wattage rating you'll need from a generator in a power outage.
- Plug AmWatt into a 120 Volt live outlet. Plug your appliance into AmWatt. Read watts (up to 1875) or amps (up to 15) on LCD display.



CHECKOUT PLUG-IN CIRCUIT ANALYZER AND GFCI CHECK

Item#	Description	UPC	Pack Qty.
THP102	Plug-In Circuit Analyzer and GFCI Check	8-15181-01066-9	5
THP102P	Plug-In Circuit Analyzer and GFCI Check - 40" Cord	8-15181-01067-6	5

- Plug CHECKOUT PRO Plug-in Circuit Analyzer into 120 Volt standard or GFCI outlet. LCD light pattern tell you of wiring flaws. Push button for GFCI check.



PIVI PLUG-IN VOLTAGE INDICATOR

Item#	Description	UPC	Pack Qty.
THP105	Plug-In Voltage Indicator	8-51890-00056-0	5

- Plug PIVI into any home or portable generator outlet. Read the voltage level output on the LED lights
- Voltage Readings: RED- Too High (over 132 Volts) = can damage home devices; GREEN- Good (108-132 Volts) = home devices are safe; AMBER- Too Low = can damage home devices.

POWEROUT! POWER FAILURE EMERGENCY LIGHT

Item#	Description	UPC	Pack Qty.
THP207M	Power Failure Emergency Light & Alarm	8-51890-00062-1	5

- A compact plug-in emergency light and alarm. Under normal utility power conditions the PowerOUT is a subtle night light. But when a power outage occurs, it becomes a 78dB alarm with a powerful LED path- or portable flashlight that lasts up to 3 hours.



EARLY WARNING SUMP PUMP ALARM & FLOOD ALERT

Item#	Description	UPC	Pack Qty.
THP205	Sump Pump Alarm and Flood Alert	8-51890-00061-4	5

- Our simple and effective sump pump alarm is designed to sound an extra-loud 105dB alarm when the water in a basement sump pump crock rises to warn you of basement flooding. Accessory suction cup on sensor for use in laundry rooms.
- Features include
 - Wall-mountable
 - 6-foot sensor probe wire with crimp-on sinker weight to allow sensor to hang in sump crock at correct level.



SONICORD KEY APPLIANCE POWER FAILURE ALARM

Item#	Description	UPC	Pack Qty.
THP111	Plug-In Appliance Load Tester	8-15181-01056-0	3

- This alarm plugs IN-LINE between the power outlet and the appliance being monitored. It sounds a piercing 104 dB alarm for 90 seconds when power is cut-off to the appliance. Great for refrigerators, freezers, aquariums, wine coolers. Uses 2 rechargeable batteries (included).

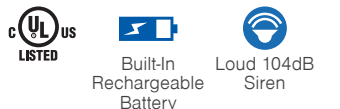

PHONE-OUT FREEZE ALARM FOR HOME OR CABIN

Item#	Description	UPC	Pack Qty.
THP217	Alarm for Home or Cabin	8-51890-00099-7	3

- This alarm connects to the land line phone in your home or cabin. It lets you program five numbers to call you or neighbors when room temperatures drop below 42 degrees.
- Keypad base plugs into phone line and electrical outlet.
- Tone alarm on phone call received.
- FCC approved



POWERBACK UTILITY POWER RETURN WARNING ALERT

Item#	Description	UPC	Pack Qty.
THP108	Plug-In Voltage Indicator	8-15181-01055-3	1

- PowerBACK connects wirelessly to your main electrical panel to alert you when utility power returns after a power outage. For use when entire panel is shut down while a generator is used.





RelianceControls.com